

Einbauanleitung Mounting instruction Montagehandleiding Instructions de montage Istruzioni di montaggio

Swift

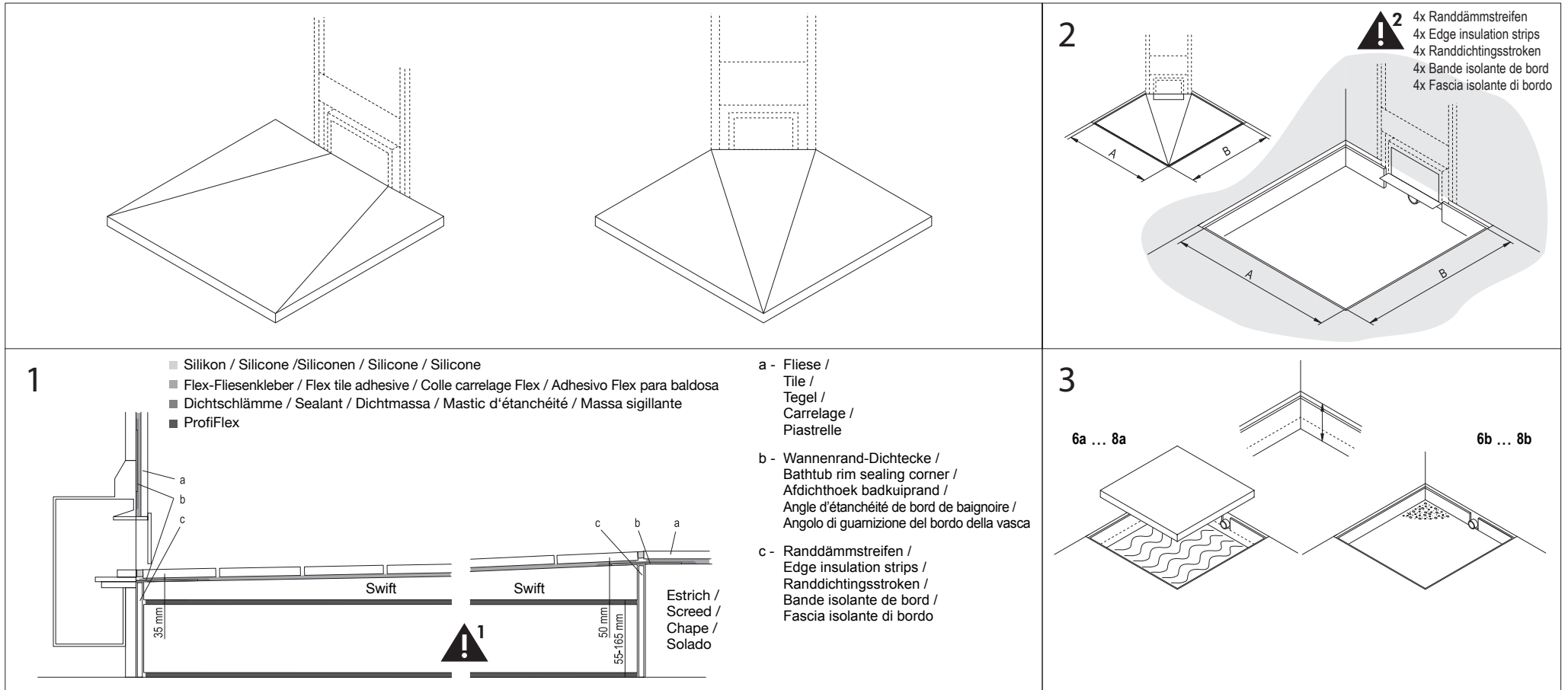

4

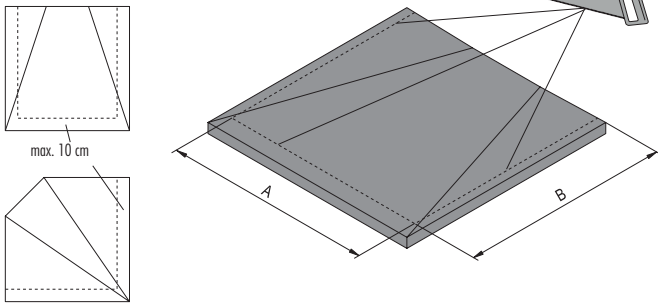

5

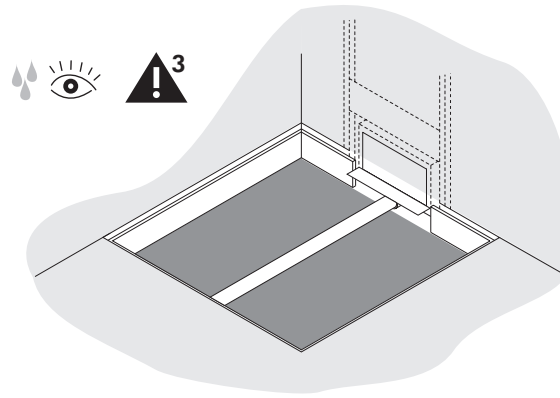

6a

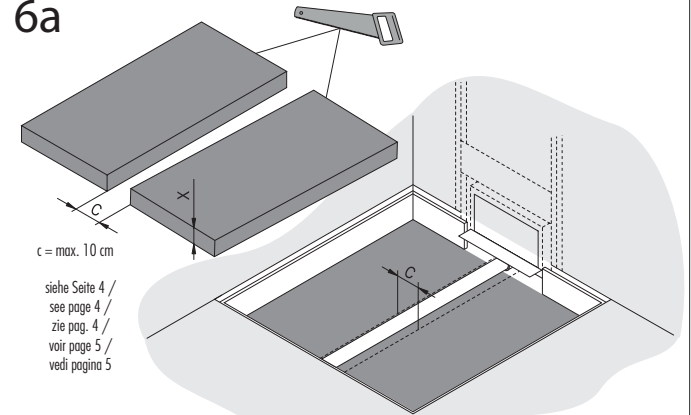

7a

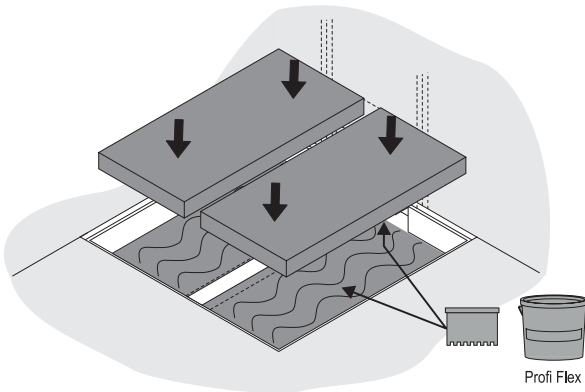

8a

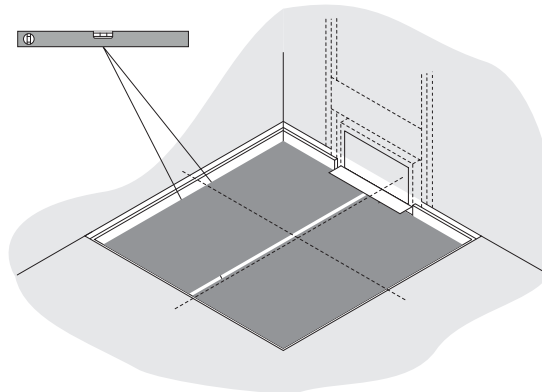

6b

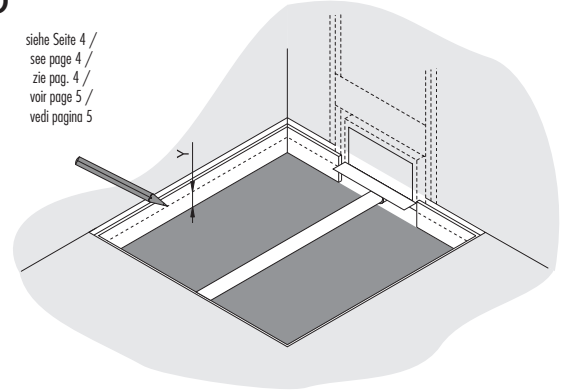

7b

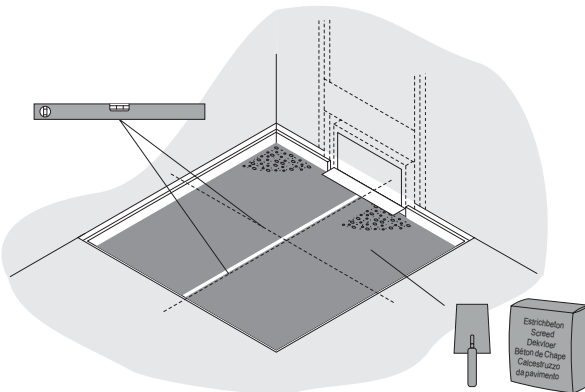

9

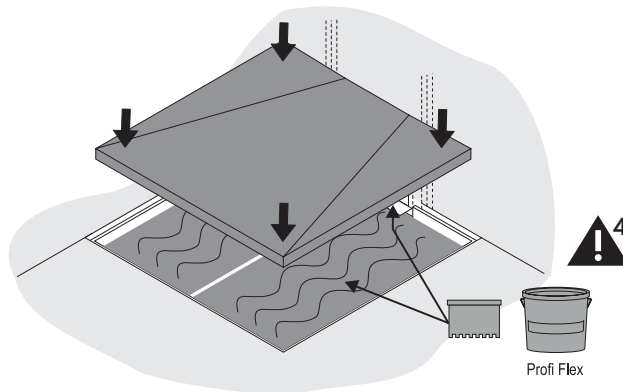

10

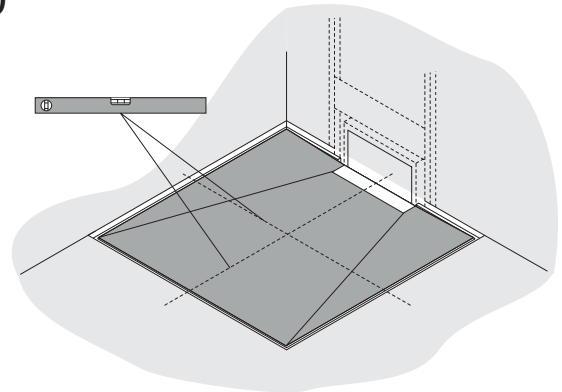

11

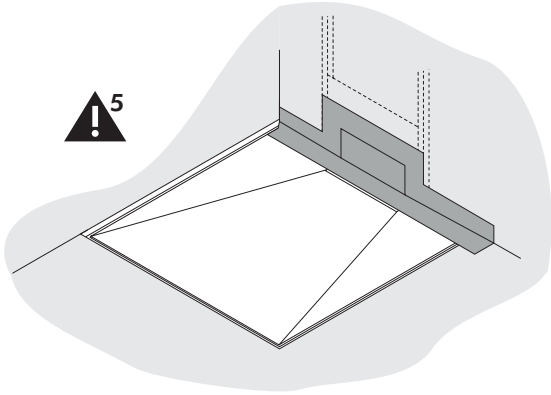

12

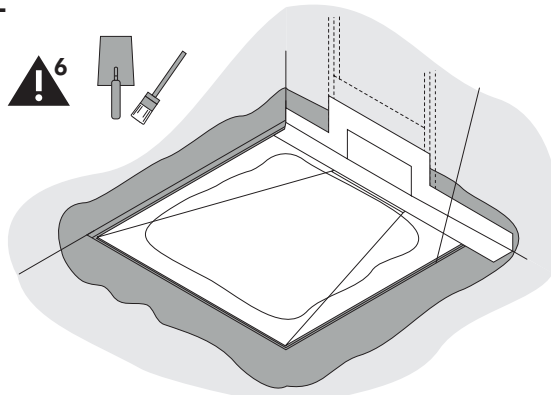

13

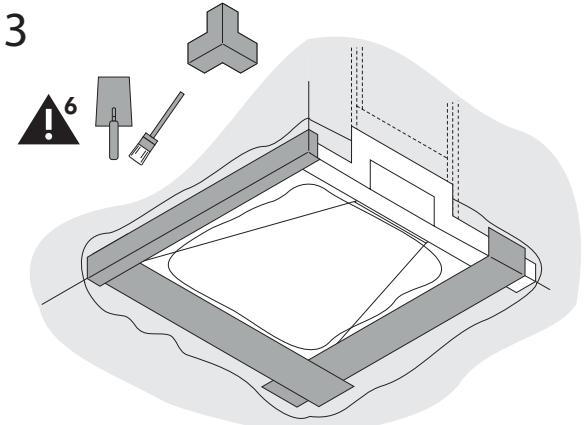
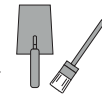

14



min. 24 h

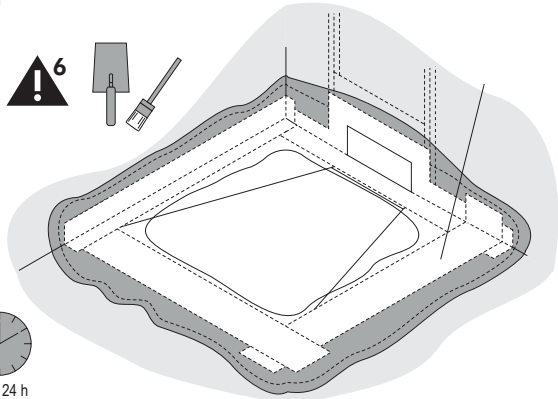

15

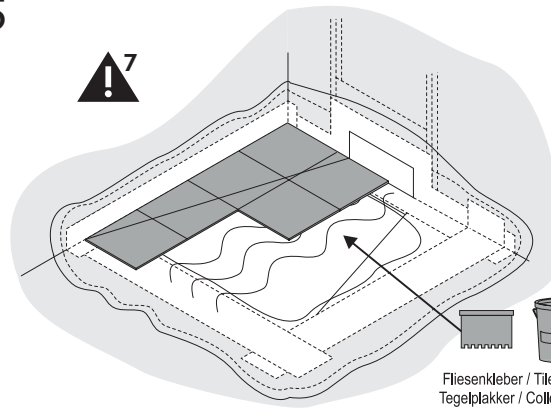

Fliesenkleber / Tile adhesive /
Tegetplakker / Colle carrelage /
Collante per piastrelle

16

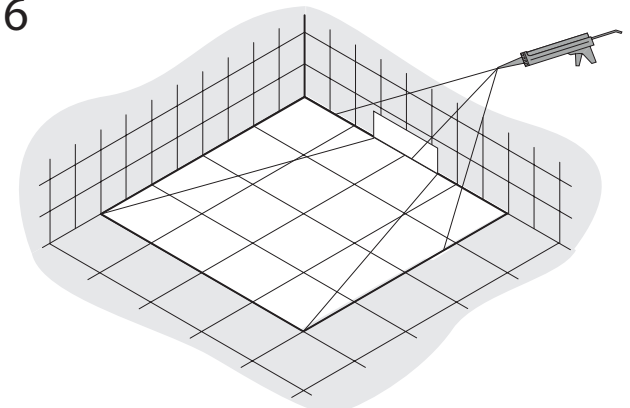

Verwendung:

- Das Gefälleelement Swift kann vom Verarbeiter unter Berücksichtigung der Geometrie und Einbauhöhe, mit Ausnahme der Ablaufseite, um bis zu 100 mm gekürzt werden.
- Die Art und Weise der Nutzung des Duschplatzes (Spritzschutz, Bewegungsfläche etc.) ist zu berücksichtigen.
- Für den Einbau des Gefälleelements muss ein ebener, sauberer, tragfähiger, schwingungsfreier und für die Verklebung mit Profi Flex zementärer Kleber geeigneter Untergrund vorhanden sein.
- Das Gefälleelement ist generell rollstuhlbefahrbar unter Verwendung von Fliesen mit einer Mindestgröße 100 x 100 mm. Bei Einarbeitung eines Glasgewebes in das Fliesenkleberbett können auch Fliesen mit einer Mindestgröße 50 x 50 mm verwendet werden.
- Nur für den Einsatz im Innenbereich geeignet.

 Die Einbauanleitung für das Geberit Duschelement ist zu beachten.

 Die einschlägigen Verarbeitungsrichtlinien aller beteiligten Gewerke sind zu berücksichtigen.

 ¹ Beim Einbau müssen Unterbauelemente (nicht im Lieferumfang, siehe Abb. 6a bis 8b) oder ein gegossener Estrichsockel (siehe Abb. 6b bis 7b) verwendet werden. Die Höhe des Unterbauelementes/Estrichsockels ist anhand des Höhenunterschiedes zwischen Rohfußboden und Raumestrich zu wählen (siehe auch Einbaubeispiele).

 ² Randdämmstreifen sind bauseits zu stellen.

 ³ Nach Installation der Ablaufgarnitur ist eine Dichtigkeitsprüfung durchzuführen.

 ⁴ Profi Flex beidseitig auftragen.

 ⁵ Das Geberit-Abdichtset (nicht im Lieferumfang) ist zu verwenden.

 ⁶ Die Verarbeitungshinweise des Abdichtsystems sind zu beachten.

 ⁷ Für den jeweiligen Fliesenbelag geeigneten Fliesenkleber und Fugenmörtel sind zu verwenden.

Einbaubeispiel mit Unterbauelement (X):

Aufbauhöhe/Fertigfußboden	120 mm
Swift	- 50 mm
2 Lagen Profi Flex	-10 mm
Unterbauelement (X)	= 60 mm

Einbaubeispiel mit Estrichsockel (Y):

Aufbauhöhe/Fertigfußboden	120 mm
Swift	- 50 mm
1 Lage Profi Flex	- 5 mm
Estrichsockel (Y)	= 65 mm

Das Duschsystem Swift erfüllt in eingebauten Zustand die Anforderungen an Baustoffe der Baustoffklasse B2 nach DIN 4102-1 (normalentflammbar) der Klasse E nach DIN EN 1350-1.

Use:

- The Swift slope element can be shortened by the installer by up to 100 mm, with the exception of the drain side, considering the geometry and installation height.
- The kind of utilization of the shower space (splash protection, movement area, etc.) is to be considered.
- For installation of the shower system, a flat, clean, firm and vibration-less substrate suitable for fastening with Profi Flex cement adhesive is required.
- The slope element is generally wheelchair-accessible, using tiles of a minimum size of 100 x 100 mm. When a fiberglass cloth is incorporated in the tile adhesive bed it is also possible to use tiles of a minimum size of 50 x 50 mm.
- Suitable for indoor use only.

 The installation instructions for the Geberit shower element are to be observed.

 The relevant working guidelines of all the trades involved shall be observed.

 ¹ When installing foundation elements (not included in the scope of supply, see Figs. 6a to 8b) or a cast screed base (see Figs. 6b to 7b) must be used. The height of the foundation element/screed base is to be chosen according to the difference in level between the unfinished floor and flooring screed (also see installation examples).

 ² Edge insulation strips are to be provided by the owner.

 ³ After the installation of the drain fitting, a leak test has to be carried out.

 ⁴ Profi Flex must always be applied to both sides.

 ⁵ The Geberit sealing set (not included in the scope of supply) is to be used.

 ⁶ The processing instructions for the sealing system shall be observed.

 ⁷ Use the tile adhesive and joint mortar for the respective tile flooring.

Example for installation with substructure element (X):

Mounting height/finished floor level	120 mm
Swift	- 50 mm
2 layers of Profi Flex	-10 mm
Substructure element (X)	= 60 mm

Installation example with screed base (Y):

Mounting height/finished floor level	120 mm
Swift	- 50 mm
1 layer of Profi Flex	- 5 mm
Screed base (Y)	= 65 mm

The shower system Swift meets the requirements relating to the construction materials of construction material class B2 according to DIN 4102-1 (normally inflammable) of class E according to DIN EN 1350-1 in installed condition.

Toepassing:

- Het afschotelement Swift kan door de gebruiker tot 100 mm worden ingekort, daarbij rekening houdend met de grootte en, inbouwhoogte, met uitzondering van de afvoerzijde.
- Er moet ook rekening worden gehouden met de gebruikswijze van de douche (spatbescherming, bewegingsruimte enz.).
- Voor montage van het afschotelement moet een vlakke, schone en zonder vibratie dragende ondergrond aanwezig zijn, die geschikt is voor het plakken met cementgebonden lijm Profi Flex.
- Het afschotelement kan over het algemeen met een rolstoel worden gereden bij gebruikmaking van tegels met een minimale grootte van 100 x 100 mm. Bij verwerking van glasweefsel in het lijmbed van de tegels kunnen ook tegels met een minimum grootte van 50 x 50 mm worden gebruikt.
- Alleen geschikt voor de toepassing binnen.

 De montagehandleiding voor het Geberit douche-element moet in acht worden genomen.

 Rekening houden met de verwerkingsrichtlijnen van alle betrokken leveranciers.

 ¹ Bij de montage moeten onderbouwdelementen (niet bij de levering inbegrepen, zie afb. 6a tot 8b) of een gegoten estriksokkel (zie afb. 6b tot 7b) worden gebruikt. De hoogte van het onderbouwdelement/estriksokkel moet aan hand van het hoogteverschil tussen ruwe vloer en ruimte-estrik worden gekozen (zie ook montagevoorbeelden).

 ² Randafdichtstroken moeten op de bouwplaats beschikbaar worden gesteld.

 ³ Na installatie van de afvoergarnituur op dichtheid testen.

 ⁴ Profi Flex aan beide kanten aanbrengen.

 ⁵ Het afdichtstelsel van de gootfabrikant moet worden gebruikt (niet bij de levering inbegrepen).

 ⁶ De verwerkingsrichtlijnen van het afdichtstelsel moeten worden aangehouden.

 ⁷ Gebruik voor de betreffende tegelbekleding geschikte tegelijm en voegmörtel.

Montagevoorbeeld met Onderbouwelement (X):	
Opbouwhoogte/afgewerkte vloer	120 mm
Swift	- 50 mm
2 lagen Profi Flex	-10 mm
Onderbouwelement (X)	= 60 mm

Montagevoorbeeld met Estrikondergrond (Y):	
Opbouwhoogte/afgewerkte vloer	120 mm
Swift	- 50 mm
1 laag Profi Flex	- 5 mm
Estrikondergrond (Y)	= 65 mm

Het douchesysteem Swift voldoet in ingebouwde toestand aan de eisen voor bouwmaterialen van brandklasse B2 conform DIN 4102-1 (normaal ontvlambaar) van klasse E conform DIN-EN 1350-1.

Utilisation:

- L'élément incliné Swift peut être raccourci par l'installateur de jusqu'à 100 mm, exception faite du côté d'écoulement, en tenant compte de la géométrie et de la hauteur hors tout.
- Il faut prendre en considération le mode d'utilisation du poste de douche (protection contre la projection de gouttes d'eau, espace de mouvement etc.).
- Pour le montage de l'élément incliné, il faut avoir une surface plane, propre, stable, exempte de vibrations et appropriée à l'application de mortier-colle Profi Flex.
- En général, l'élément incliné est accessible en fauteuil roulant à la condition d'utiliser des carreaux de dimensions minimales de 100 x 100 mm. Si le lit de colle pour la pose des carreaux est renforcé par du tissu de verre, il est possible d'utiliser également des carreaux de dimensions minimales de 50 x 50 mm.
- Ne se prête qu'à l'utilisation à l'intérieur de la maison.



Respecter les instructions de mise en oeuvre de l'élément de douche Geberit.



Les instructions correspondantes de mise en oeuvre de tous les métiers participants sont à respecter.



1 Pour l'installation, il faut mettre en place des éléments de base (non compris dans la fourniture, voir fig. 6a à 8b) ou un socle coulé de chape (voir fig. 6b à 7b). La hauteur de l'élément de base/du socle de chape est à choisir selon la différence de hauteur entre le sol brut et la chape de la salle (voir également les exemples d'installation).



2 Les bandes isolantes sont à prévoir par le client.



3 Après le montage de la garniture d'écoulement, procéder à une épreuve d'étanchéité.



4 Appliquer la Profi Flex sur les deux faces.



5 Utiliser le jeu de matériel d'étanchéité Geberit (non compris dans la fourniture).



6 Respecter pour le système d'étanchéité le mode de mise en oeuvre.



7 Utiliser de la colle pour carreaux et du mortier de jointoiement appropriés au carrelage.

Exemple d'installation avec élément de support de base (X):	
Hauteur de montage/sol fini	120 mm
Swift	- 50 mm
2 couches de Profi Flex	-10 mm
Élément de support de base (X)	= 60 mm

Exemple d'installation avec socle de chape (Y):	
Hauteur de montage/sol fini	120 mm
Swift	- 50 mm
1 couche de Profi Flex	- 5 mm
Socle de chape (Y)	= 65 mm

Le système de douche Swift répond, à l'état monté, aux exigences sur les matériaux du bâtiment de la catégorie de matériaux B2 conformément à DIN 4102-1 (inflammable normalement) de la catégorie E conformément à DIN EN 1350-1.

Uso:

- L'elemento in pendenza Swift può essere accorciato dall'installatore di fino a 100 mm eccetto il lato di scolo e tenendo conto della geometria e dell'altezza di montaggio.
- Si deve prendere in considerazione il modo d'utilizzazione del posto di doccia (protezione contro gli spruzzi di acqua, spazio di movimento ecc.).
- Per il montaggio dell'elemento in pendenza è necessario di avere una superficie piana, pulita, stabile, esente da vibrazioni ed appropriata all'incollatura con adesivo cementizio Profi-Flex.
- L'elemento in pendenza è generalmente accessibile con sedia a rotelle a condizione d'utilizzare piastrelle a dimensioni minimali 100 x 100 mm. Se il letto di colla delle piastrelle è rinforzato da tessuto di vetro, è possibile di utilizzare anche piastrelle a dimensioni minimali 50 x 50 mm.
- Solo utilizzabile all'interno della casa.



Rispettare le istruzioni di montaggio per l'elemento di doccia Geberit.



Si deve osservare le istruzioni corrispondenti di lavorazione di tutti i mestieri partecipanti.



1 Per il montaggio sono necessari elementi di base (non compresi nella fornitura, vedi fig. 6a a 8b) o uno zoccolo colato di pavimento (vedi fig. 6b a 7b). L'altezza dell'elemento di base/zoccolo di pavimento è da scegliere secondo la differenza di altezza fra fondo grezzo e pavimento della camera (vedi anche esempi di installazione).



2 Fasce isolanti sono da prevedere dal cliente.



3 Dopo l'installazione del gruppo di scolo, si deve procedere ad una prova di tenuta.



4 Applicare Profi Flex su entrambi i lati.



5 Utilizzare il set di materiale di guarnizione Geberit (non compreso nella fornitura).



6 Le istruzioni di lavorazione per il sistema di guarnizione sono da osservare.



7 Utilizzare colla per piastrelle e malta per giunti adatte per il pavimento a piastrelle rispettivo.

Esempio d'installazione con elemento di spessore (X):	
Altezza di montaggio/ pavimento finito	120 mm
Swift	- 50 mm
N. 2 strati di Profi Flex	-10 mm
Elemento di spessore (X)	= 60 mm

Esempio d'installazione con zoccolo di pavimento (Y):	
Altezza di montaggio/ pavimento finito	120 mm
Swift	- 50 mm
N. 1 strato di Profi Flex	- 5 mm
Zoccolo di pavimento (Y)	= 65 mm

Il sistema di doccia Swift adempie alle esigenze per materiali di costruzione della classe di materiali di costruzione B2 secondo DIN 4102-1 (normalmente infiammabile) della classe E secondo DIN EN 1350-1 in stato installato.

Empfohlenes Zubehör / Recommended accessories / Aanbevolen toebehoren / Accessoires recommandés / Accessori raccomandati:

Zementärer Kleber zur Untergrundverklebung / cement adhesive for gluing on ground / cementgebonden lijm voor ondergrondverlijming / mortier-colle pour collage de supports / adesivo cementizio per incollaggio sottofondo

Dichtschlämme / Sealant / Dichtmassa / Mastic d'étanchéité / Massa sigillante

Unterbauelement / Substrate element / Onderbouwelement / Élément de réhausse / Sottostrutte

Dichtband / Sealing tape / Afdichtingsband / Bande isolante / Fascia isolante

Dichtband-Innenecke / Sealing tape interior corner / Afdichtingsband-binnenliggende hoek / Bande d'étanchéité pour coin intérieur / Fascia isolante per angolo interno

Dichtband-Außenecke / Sealing tape exterior corner / Afdichtingsband-buitenliggende hoek / Bande d'étanchéité pour coin extérieur / Fascia isolante per angolo esterno

Geeigneter Fliesenkleber / Suitable tile adhesive / Geschikte tegelplakker / Colle carrelage / Collante per piastrelle adatto

Silikon / Silicone / Siliconen / Silicone / Silicone