

Einbauanleitung Mounting instruction Montagehandleiding Instructions de montage Istruzioni di montaggio

Life

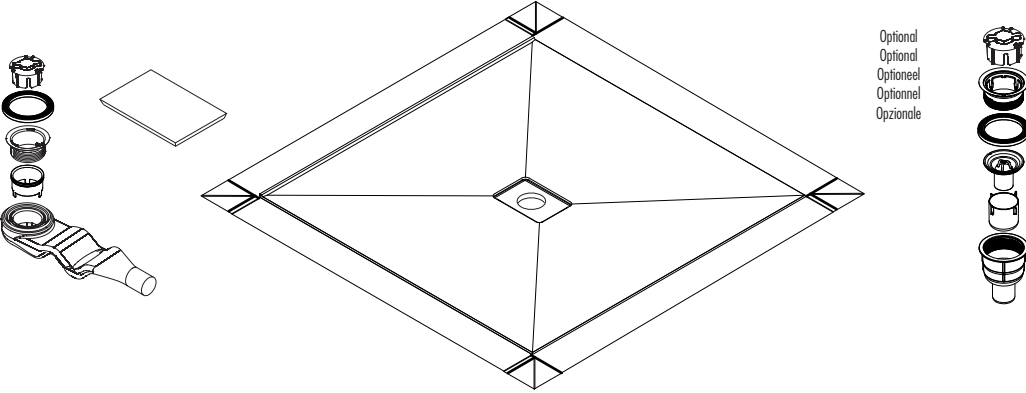

Optional
Optioneel
Optionnel
Opzionale

2

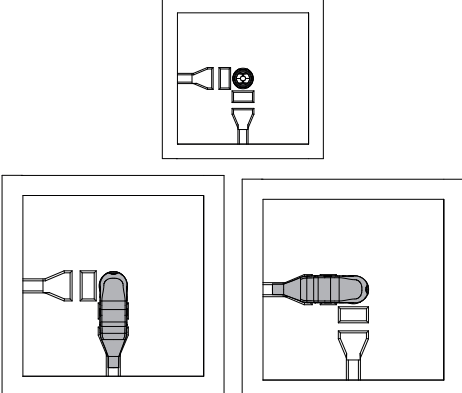

1

<p>a - Fliese / Tile / Tegel / Carrelage / Piastrelle</p>	<p>b - Flex-Fliesenkleber / Flex tile adhesive / Flex-tegelplakker / Colle carrelage Flex / Collante per piastrelle Flex</p>	<p>c - Dichtband / Sealing tape / Afdichtingsband / Bande isolante / Fascia isolante</p>	<p>d - Randdämmstreifen / Edge insulation strips / Randdichtingsstroken / Bande isolante de bord / Fascia isolante di bordo</p>	<p>e - Unterbauelement / Substrate element / Onderbouwelement / Elément de réhausse / Sottostrutte</p>
---	--	--	---	--

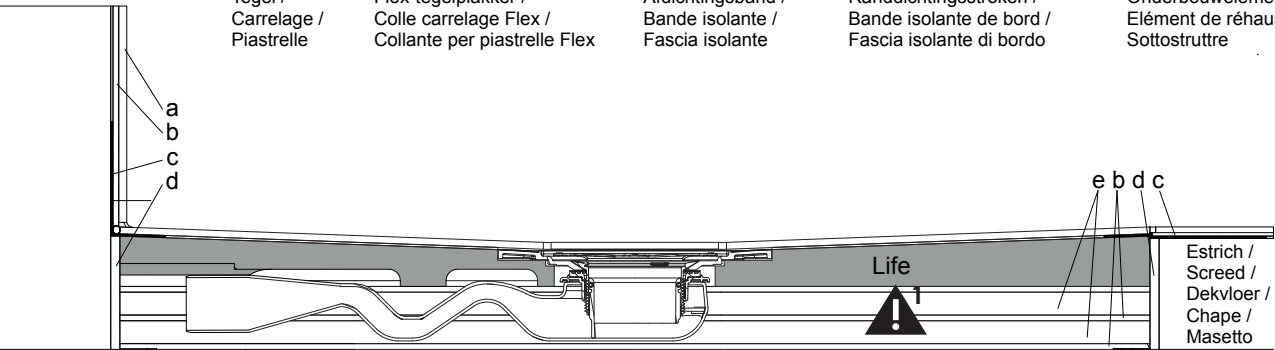

Estrich /
Screed /
Dekvloer /
Chape /
Masetto

3

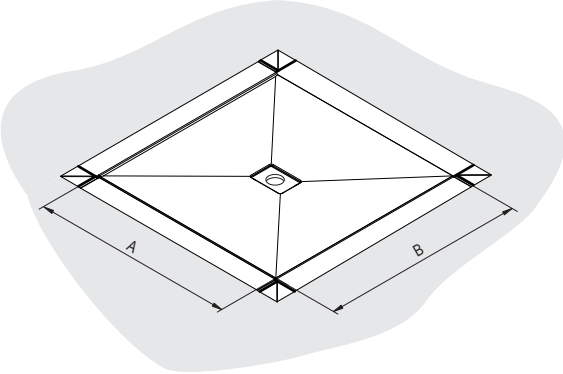

4

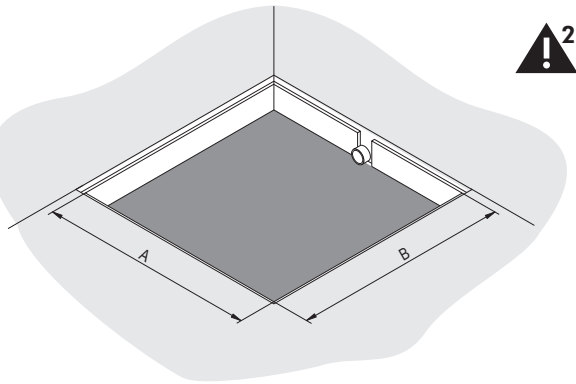

5

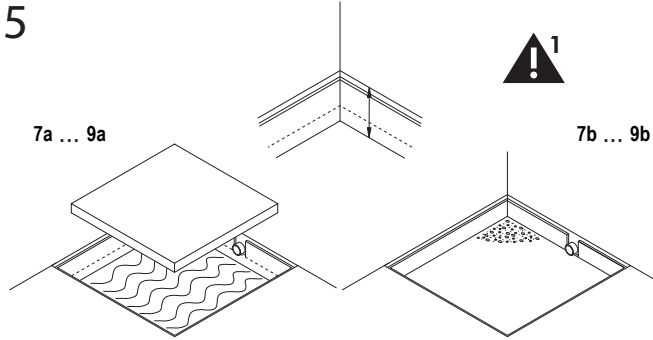

6

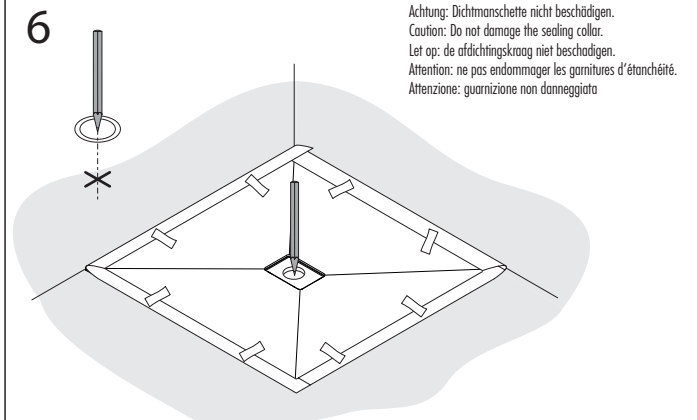

Achtung: Dichtmanschette nicht beschädigen.
 Caution: Do not damage the sealing collar.
 Let op: de afichtingskroeg niet beschadigen.
 Attention: ne pas endommager les garnitures d'étanchéité.
 Attenzione: guarnizione non danneggiata

7a

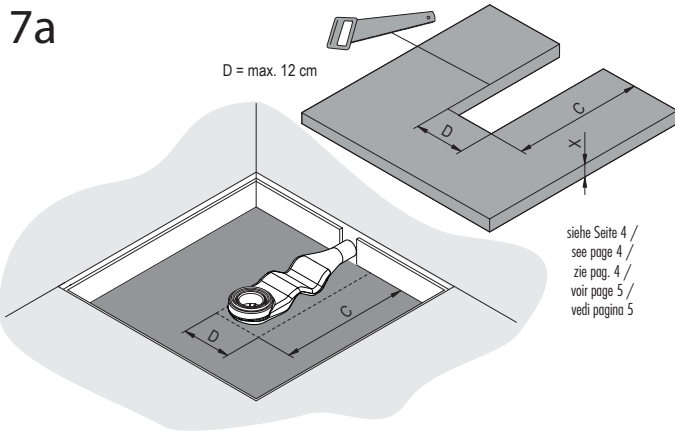

8a

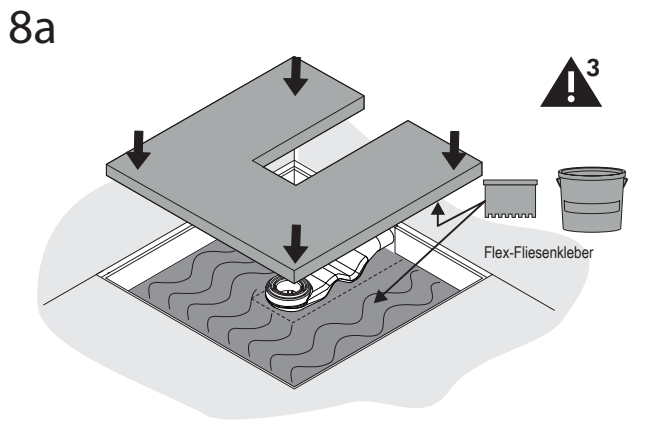

9a

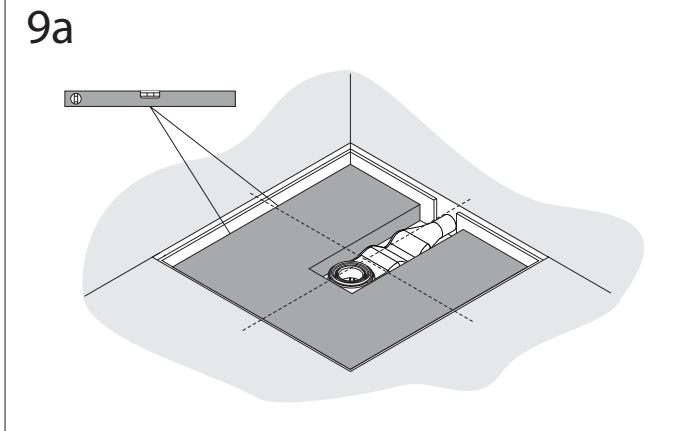

7b

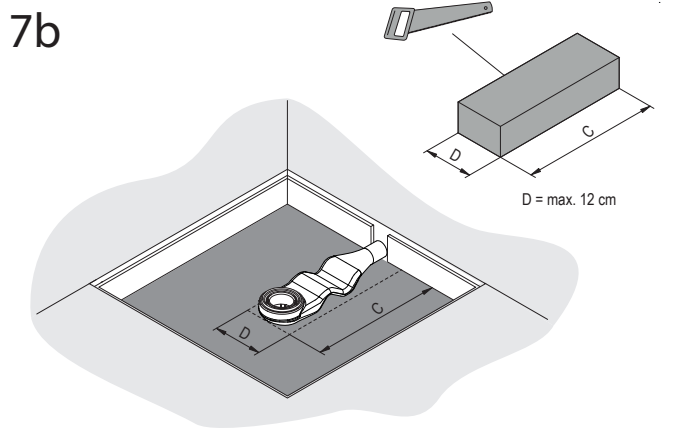

8b

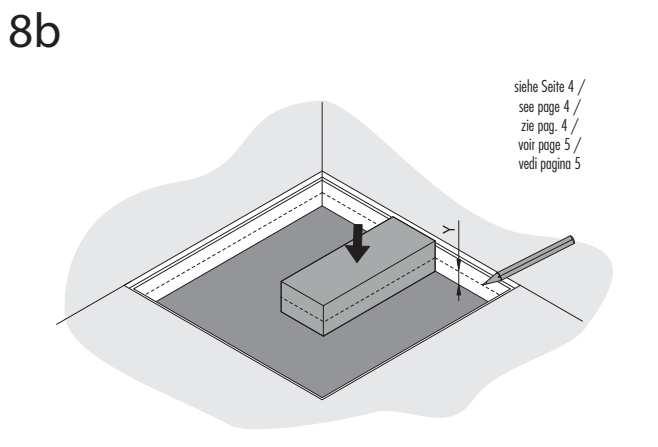

9b

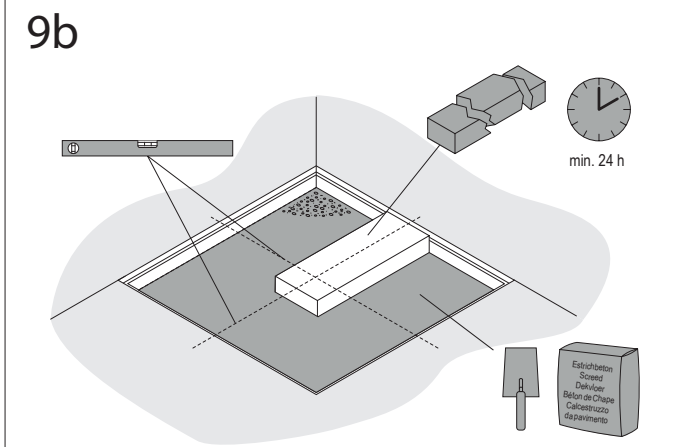

10

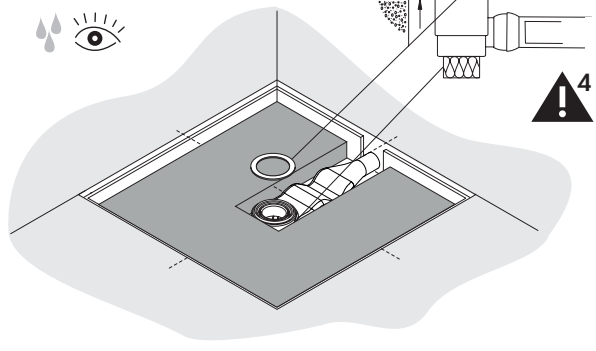

11

Achtung: Dichtmanschette nicht beschädigen.
Caution: Do not damage the sealing collar.
Let op: de afdichtingskraag niet beschadigen.
Attention: ne pas endommager les garnitures d'étanchéité.
Attenzione: guarnizione non danneggiata

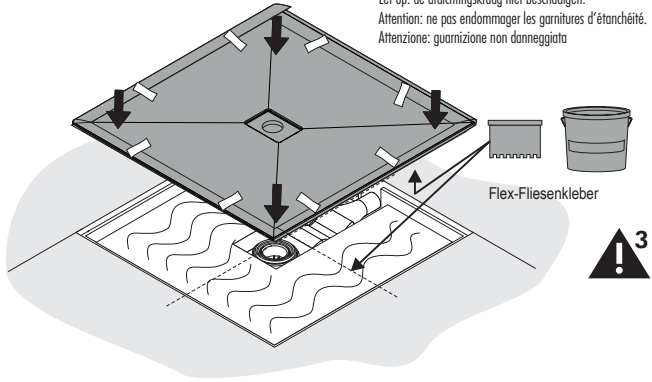

12

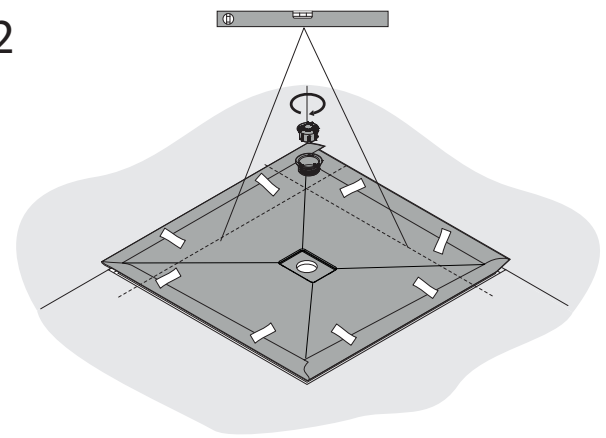

13

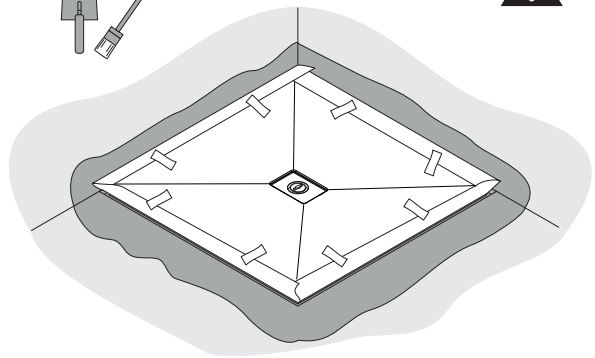
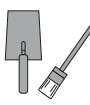

14

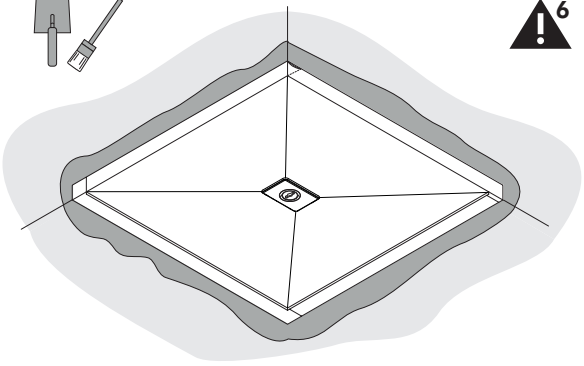
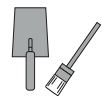

15

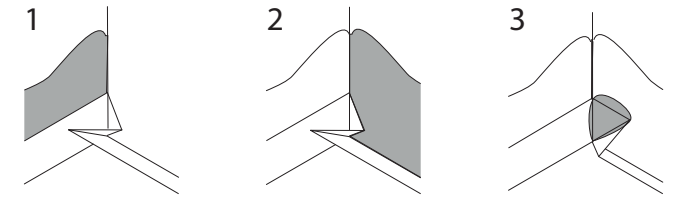

16



min. 24 h

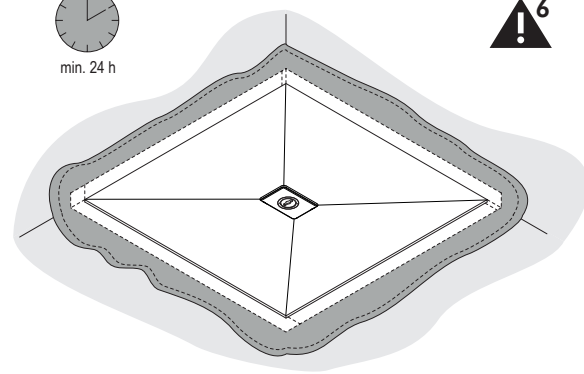

17

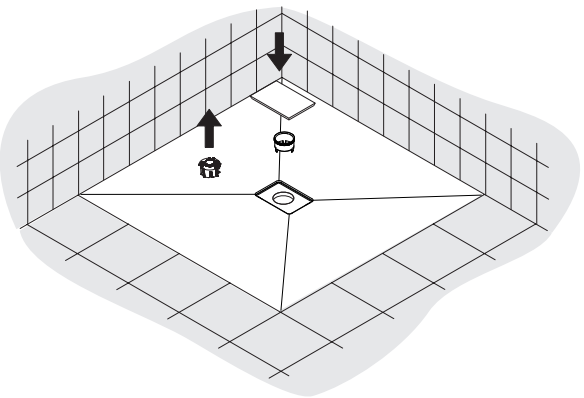

18

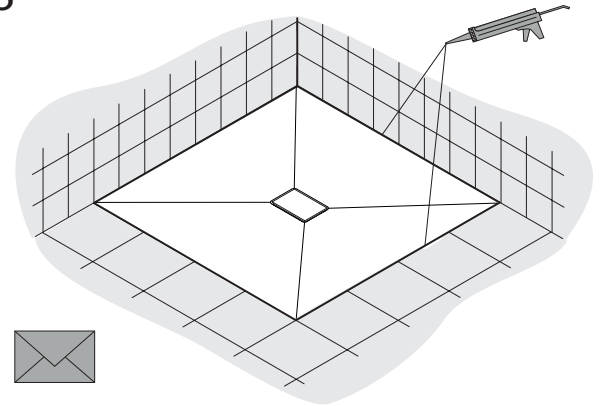

Verwendung:

- Die Größe des Duschsystems kann nicht verändert werden.
- Die Art und Weise der Nutzung des Duschplatzes (Spritzschutz, Bewegungsfläche etc.) ist zu berücksichtigen.
- Für den Einbau des Duschsystems muss ein ebener, sauberer, tragfähiger, schwingungsfreier und für die Verklebung mit Flex-Fliesenkleber geeigneter Untergrund vorhanden sein.
- Der richtige Sitz des Ablaufkörpers ist zu prüfen.
- Das Duschsystem ist generell rollstuhlfahrbar.
- Nur für den Einsatz im Innenbereich geeignet.



Die einschlägigen Verarbeitungsrichtlinien aller beteiligten Gewerke sind zu berücksichtigen.



Die Schutzfolie erst nach dem Verfliesen vom Duschsystem entfernen. Life Oberfläche bei rückseitigem Auftrag von Fliesenkleber mit untergelegter Pappe schützen.



1 Beim Einbau müssen Unterbauelemente (nicht im Lieferumfang, siehe Abb. 6a bis 8b) oder ein gegossener Estrichsockel (siehe Abb. 6b bis 8b) verwendet werden. Die Höhe des Unterbauelementes/Estrichsockels ist anhand des Höhenunterschiedes zwischen Rohfußboden und Fertigfußboden zu wählen (siehe auch Einbaubeispiele).



2 Randdämmstreifen sind bauseits zu stellen.



3 Fliesenkleber beidseitig auftragen. Auf der Unterseite der Life sind die Kanäle auszusparen.



4 Die Ablaufgarnitur muss gegebenenfalls mit geeignetem schalldämmendem Material unterlegt werden.



5 Nach Installation der Ablaufgarnitur ist eine Dichtigkeitsprüfung durchzuführen.



6 Die Verarbeitungshinweise des Abdichtsystems sind zu beachten.



7 Die Ecken des Dichtbandes an den vorgeprägten Stellen falten. Das Dichtband und die sich ergebenden Überlappungen sind vollständig mit Dichtmasse einzudichten.



Pflegeanleitung an Endkunden übergeben.

Einbaubeispiel mit Unterbauelement (X):

Aufbauhöhe/Fertigfußboden	120 mm
Life	50 mm
2 Lagen Fliesenkleber	-10 mm
Unterbauelement (X)	= 60 mm

Einbaubeispiel mit Estrichsockel (Y):

Aufbauhöhe/Fertigfußboden	120 mm
Life	50 mm
1 Lage Fliesenkleber	- 5 mm
Estrichsockel (Y)	= 65 mm

Use:

- The size of the shower system cannot be changed.
- The kind of utilization of the shower space (splash protection, movement area, etc.) is to be considered.
- For the installation of the shower system a level, clean, solid surface free of vibrations and suited for fastening with Flex tile adhesive must be available.
- The correct fitting of the discharge element is to be checked.
- The shower system is in general wheelchair-accessible.
- Suitable only for use indoor.



The relevant processing guidelines of all trades must be observed.



Remove protective foil after having tiled the shower system. When applying the tile adhesive to the back, make sure to protect the Life surface by laying it face down on cardboard.



1 For installation substructure elements (not included in supply, see figs. 6a to 8a) or a cast screed base (see figs. 6b to 8b) are to be used. The height of the substructure element/screed base is to be selected according to the difference in height between the raw floor and the room flooring (see also installation examples).



2 Edge insulation strips are to be provided locally.



3 Apply tile adhesive to both sides. The channels on the underside of the Life should be left clear.



4 The drain fitting must possibly be lined with suitable sound absorbing material.



5 After the installation of the drain fitting, a leakage test must be carried out.



6 The processing instructions of the sealing system are to be observed.



7 Fold the corners of the sealing tape at the pre-marked points. The sealing tape and the resulting overlaps must be completely sealed with sealing compound.



Give the care instructions to the end customer.

Example for installation with substructure element (X):

Mounting height/finished floor level	120 mm
Life-	50 mm
2 layers of tile adhesive	-10 mm
Substructure element (X)	= 60 mm

Installation example with screed base (Y):

Mounting height/finished floor level	120 mm
Life	50 mm
1 layer of tile adhesive	- 5 mm
Screed base (Y)	= 65 mm

Toepassing:

- De grootte van het douchesysteem kan niet worden gewijzigd.
- Er moet ook rekening worden gehouden met de gebruikswijze van de douche (spatbescherming, bewegingsruimte enz.).
- Voor de montage van het douchesysteem moet een vlakke, schone, draagkrachtige, trivrije en voor verwerking van de Flex-tegelplakker geschikte ondergrond aanwezig zijn.
- De correcte zitting van het aflooplelement moet worden gecontroleerd.
- Het douchesysteem is over het algemeen rolstoelgeschikt.
- Alleen geschikt voor toepassing in binnenuimte.



Met de betreffende verwerkingsrichtlijnen van alle betrokken onderdelen moet rekening worden gehouden.



Verwijder de beschermfolie van het douchesysteem pas als de tegels zijn gelegd. Als op de achterzijde tegellijn wordt aangebracht, Life beschermen door met het oppervlak naar beneden op karton te leggen.



1 Bij inbouwen moeten de onderbouwelementen (niet in de levering inbegrepen, zie afb. 6a t/m 8b) of een gegoten estrikondergrond (zie afb. 6b t/m 8b) worden toegepast. De hoogte van het onderbouwelement/estrikondergrond moet aan de hand van het hoogteverschil tussen onafgewerkte vloer en kamerestrik worden gekozen (zie ook installatievoorbeelden).



2 Randdichtingsstroken zijn niet in de levering inbegrepen.



3 Tegelplakker aan beide kanten aanbrengen. Aan de onderzijde van Life moeten de kanalen worden uitgespaard.



4 De afvoergarnitur moet eventueel met geschikt geluiddempend materiaal worden geïsoleerd.



5 Na de installatie van de waterafvoer moet een dichtheidscontrole worden uitgevoerd.



6 De verwerkingsaanwijzingen van het afdichtsysteem moeten worden opgevolgd.



7 De hoeken van de afdichtingstape vouwen op de voor-gepreegde punten. De afdichtingstape en de overlappenden ervan moeten volledig worden afgedicht met voegmiddel.

 Onderhoudsinstructies aan de eindklant overhandigen.

Montagevoorbeeld met onderbouwelement (X):

Opbouwhoogte/afgewerkte vloer	120 mm
Life	50 mm
2 lagen tegelplakker	-10 mm
Onderbouwelement (X)	= 60 mm

Montagevoorbeeld met estrikondergrond (Y):

Opbouwhoogte/afgewerkte vloer	120 mm
Life	50 mm
1 laag tegelplakker	- 5 mm
Estrikondergrond (Y)	= 65 mm

Utilisation:

- La grandeur du système de douche ne peut pas être modifiée.
- Il faut prendre en considération le mode d'utilisation du poste de douche (protection contre la projection de gouttes d'eau, espace de mouvement etc.).
- Pour l'installation du système de douche, il est nécessaire de disposer d'une surface de base plane, propre, capable de porter le système, antivibratoire et appropriée à l'application de la colle carrelage Flex.
- L'ajustement correct de l'élément d'écoulement est à contrôler.
- En général, le système de douche est accessible en fauteuil roulant.
- Ne se prête qu'à l'installation à l'intérieur de bâtiments.



Les directives correspondantes de mise en oeuvre de tous les métiers participants sont à observer.



N'enlever la feuille de protection du système de douche qu'après la pose des carreaux. Protéger la surface Life avec du carton placé en dessous en cas d'application de colle à carrelage sur la partie inférieure.



1 Pour l'installation, il faut utiliser des éléments de support de base (pas compris dans la fourniture, voir fig. 6a - 8b) ou un socle de chape coulée. (voir fig. 6b - 8b). Choisir la hauteur de l'élément de support de base/du socle de chape selon la différence de hauteur entre le sol brut et la chape de la salle (voir exemples d'installation).



2 Les bandes isolantes de bord sont à prévoir par le client.



3 Appliquer de colle pour carreaux sur les deux faces. Il faut éviter les canaux sur la partie inférieure du Life.



4 Le cas échéant, de la matière insonorisante doit être posée sous la garniture d'écoulement.



5 Après installation de la garniture d'écoulement, procéder à un essai d'étanchéité.



6 Respecter les instructions de mise en oeuvre du système d'étanchéité.



7 Plier les coins de la bande d'étanchéité sur les zones préparées. La bande d'étanchéité et les chevauchements doivent être recouverts intégralement de mastic.



Remettre la notice d'entretien au client final.

Exemple d'installation avec élément de support de base (X):

Hauteur de montage/sol fini	120 mm
Life	50 mm
2 couches de colle pour carreaux	-10 mm
Élément de support de base (X)	= 60 mm

Exemple d'installation avec socle de chape (Y):

Hauteur de montage/sol fini	120 mm
Life	50 mm
1 couche de colle pour carreaux	- 5 mm
Socle de chape (Y)	= 65 mm

Usò:

- La grandezza del sistema di doccia non può essere modificata.
- Si deve prendere in considerazione il modo d'utilizzazione del posto di doccia (protezione contro gli spruzzi di acqua, spazio di movimento ecc.).
- Per l'installazione del sistema doccia deve esistere un sottosuolo piano, pulito, solido, libero di vibrazioni e adatto per l'incollaggio per mezzo del collante per piastrelle Flex.
- L'aggiustaggio corretto dell'elemento di scolo è da controllare.
- Generalmente il sistema di doccia è accessibile in sedia a rotelle.
- Adatto solo per l'uso interno.



Si deve osservare le istruzioni di lavorazione di tutti i mestieri partecipanti.



Togliere la foglia protettiva dal sistema di doccia soltanto dopo la posa delle piastrelle. Proteggere la superficie Life con un cartone mentre si spalma la colla per piastrelle sul retro.



1 Per l'installazione elementi di spessore (non compresi nella consistenza di fornitura, vedi anche fig. 6a - 8b) o uno zoccolo di pavimento continuo (vedi fig. 6b - 8b) devono essere usati. L'altezza dell'elemento di spessore/dello zoccolo di pavimento deve essere scelta secondo la differenza d'altezza tra fondo grezzo e pavimento camera (vedi anche esempi d'installazione).



2 Fasce isolanti di bordo devono essere messe a disposizione localmente.



3 Applicare l'adesivo per piastrelle su entrambi i lati. Evitare i canali sulla parte inferiore del Life.



4 L'elemento di scarico deve essere rivestito in caso con materiale isolante addetto.



5 Dopo l'installazione dell'elemento di scarico, si deve procedere ad una prova d'ermeticità.



6 Le istruzioni di lavorazione del sistema di guarnizione devono essere osservate.



7 Piegare gli angoli del nastro di sigillatura nelle aree evidenziate. Il nastro di sigillatura e le sovrapposizioni vanno sigillati completamente con il materiale di tenuta.



Consegnare le istruzioni di cura al cliente finale.

Esempio d'installazione con elemento di spessore (X):

Altezza di montaggio/ pavimento finito	120 mm
Life	50 mm
N. 2 strati di collante per piastrelle	-10 mm
Elemento di spessore (X)	= 60 mm

Esempio d'installazione con zoccolo di pavimento (Y):

Altezza di montaggio/ pavimento finito	120 mm
Life	50 mm
N. 1 strato di collante per piastrelle	- 5 mm
Zoccolo di pavimento (Y)	= 65 mm

Empfohlenes Zubehör / Recommended accessories / Aanbevolen toebehoren / Accessoires recommandés / Accessori raccomandati:

Profi-Flex-Schnellkleber / Profi-Flex fast-setting adhesive / Profi-Flex-snelplakker / Colle Profi-Flex / Collante rapido Profi-Flex

Abdichtungssystem / Sealing system / Afdichtingsysteem / Mastic d'étanchéité / Sistema di guarnizione

Unterbauelement / Substrate element / Onderbouwelement / Élément de réhausse / Sottostrutture

Silikon / Silicone / Siliconen / Silicone / Silicone

Randdämmstreifen
Edge insulation strips
Randdichtungsstroken
Bande isolante de bord
Fascia isolante di bordo

Abdichtungssystem
Sealing system
Afdichtingsysteem
Système d'étanchéité
Sistema di guarnizione